

ANSI/IEEE C37.60-1981

(IEEE Reaffirmed 1986)

(ANSI Reaffirmed 1988)

(Revision of ANSI C37.60-1974)

An American National Standard

IEEE Standard Requirements for Overhead, Pad Mounted, Dry Vault, and Submersible Automatic Circuit Reclosers and Fault Interrupters for AC Systems

Sponsor

**Switchgear Committee
of the
IEEE Power Engineering Society**

Secretariat

**Institute of Electrical and Electronics Engineers
National Electrical Manufacturers Association**

Approved March 15, 1979
Reaffirmed December 11, 1986
Reaffirmed June 18, 1992

IEEE Standards Board

Approved November 25, 1980
Reaffirmed May 10, 1988
Reaffirmed July 26, 1993

American National Standards Institute

©Copyright 1981 by

**The Institute of Electrical and Electronics Engineers, Inc
345 East 47th Street, New York, NY 10017, USA**

No part of this publication may be reproduced in any form, in an electronic retrieval system or otherwise, without the prior written permission of the publisher.

IEEE Standards documents are developed within the Technical Committees of the IEEE Societies and the Standards Coordinating Committees of the IEEE Standards Board. Members of the committees serve voluntarily and without compensation. They are not necessarily members of the Institute. The standards developed within IEEE represent a consensus of the broad expertise on the subject within the Institute as well as those activities outside of IEEE which have expressed an interest in participating in the development of the standard.

Use of an IEEE Standard is wholly voluntary. The existence of an IEEE Standard does not imply that there are no other ways to produce, test, measure, purchase, market, or provide other goods and services related to the scope of the IEEE Standard. Furthermore, the viewpoint expressed at the time a standard is approved and issued is subject to change brought about through developments in the state of the art and comments received from users of the standard. Every IEEE Standard is subjected to review at least once every five years for revision or reaffirmation. When a document is more than five years old, and has not been reaffirmed, it is reasonable to conclude that its contents, although still of some value, do not wholly reflect the present state of the art. Users are cautioned to check to determine that they have the latest edition of any IEEE Standard.

Comments for revision of IEEE Standards are welcome from any interested party, regardless of membership affiliation with IEEE. Suggestions for changes in documents should be in the form of a proposed change of text, together with appropriate supporting comments.

Interpretations: Occasionally questions may arise regarding the meaning of portions of standards as they relate to specific applications. When the need for interpretations is brought to the attention of IEEE, the institute will initiate action to prepare appropriate responses. Since IEEE Standards represent a consensus of all concerned interests, it is important to ensure that any interpretation has also received the concurrence of a balance of interests. For this reason IEEE and the members of its technical committees are not able to provide an instant response to interpretation requests except in those cases where the matter has previously received formal consideration.

Comments on standards and requests for interpretations should be addressed to:

Secretary, IEEE Standards Board
345 East 47th Street
New York, NY 10017
USA

Foreword

(This Foreword is not a part of ANSI/IEEE C37.60-1981, IEEE Standard Requirements for Overhead, Pad Mounted, Dry Vault, and Submersible Automatic Circuit Reclosers and Fault Interrupters for AC Systems.)

This Standard is a revised and updated version of ANSI/IEEE C37.60-1974, incorporating significant improvements which reflect the present state of the art in recloser technology. These include changes and additions in the following areas:

- 1) Expansion of the standard to include pad mounted and submersible reclosers
- 2) Inclusion of information for reclosers utilizing vacuum interrupters
- 3) New and expanded information related to interrupting tests, particularly for (a) cable charging currents, (b) transformer magnetizing currents, and (c) load currents
- 4) The addition of surge withstand capability requirements for recloser control elements
- 5) Expanded production test requirements

Also included is the recognition of the need for partial discharge tests for some types of reclosers. While the procedure and related requirements have not yet been finalized, (see 6.6), effort is presently underway to develop this information, and it will be published after it has been completed and has gone through the full approval process.

The Standards Committee on Power Switchgear, C37, which reviewed and approved this standard, had the following personnel at the time of approval:

C. L. Wagner, *Chair*

J. E. Beehler (*Executive Vice-Chairman of High Voltage Switchgear Standards*)

W. E. Laubach (*Executive Vice-Chairman of Low Voltage Switchgear Standards*)

S. H. Telander (*Executive Vice-Chairman of IEC Activities*)

J. D. Hopkins, *Secretary*

Organization Represented

Name of Representative

Association of American Railroads

Vacant

Association of Iron and Steel Engineers

J. M. Tillman

Electric Light and Power Group

J. E. Beehler
R. L. Capra (*Alt*)
H. G. Darron
H. F. Frus
K. D. Hendrix
R. L. Lindsey (*Alt*)
J. P. Markey (*Alt*)
E. E. Ramm (*Alt*)
D. O. Craghead

Institute of Electrical and Electronics Engineers

M. J. Beachy (*Alt*)
H. H. Fahnoe
R. E. Friedrich
M. J. Maier
C. A. Mathews (*Alt*)
H. W. Mikulecky D. C.
Musgrave (*Alt*)
C. A. Schwalbe
G. W. Walsh

National Electrical Manufacturers Association

J. L. Drown
R. W. Dunham
D. G. Portman
G. A. Wilson
W. R. Wilson

Tennessee Valley Authority

Robert C. St. Clair

Testing Laboratory Group

L. Frier
E. J. Huber
R. W. Seelbach (*Alt*)

U.S. Department of the Army

Robert H. Bruck

U.S. Department of the Interior, Bureau of Reclamation

Edward M. Tomsic

U.S. Department of Defense, Defense Communications Agency

Vacant

U.S. Department of the Navy, Naval Construction Battalion Center

A. R. Hanks
J. N. Montagna

At the time this standard was approved, the Reclosers and Sectionalizers Subcommittee of the IEEE Switchgear Committee had the following membership:

P. C. Lyons, *Chair*

R. H. Arndt
M. J. Beachy
G. W. Dolloff
R. Donnelly
R. A. Few

G. Genest
P. F. Johnson
L. V. McCall
R. H. Miller
N. L. Paulson

J. C. W. Ransom
D. R. Shapleigh
R. Singer
K. Spuhler
B. F. Wirtz

The NEMA Technical Committee on Automatic Circuit Reclosers which prepared Tables 2 through 7 and approved this standard had the following membership:

R. A. Few, *Chair*
D. Polasky, *Secretary*

R. E. Bennet
C. A. Popeck

John G. Leach
James C. W. Ransom

Clarence L. Welter
D. F. Winter

The C37 Subcommittee on Automatic Circuit Reclosers and Line Sectionalizers which approved this standard had the following membership:

B. H. Schulz, *Chair*
D. Polasky, *Secretary*

R. H. Arndt
M. J. Beachy
R. Bergstrom
H. L. Caldwell
R. L. Capra
G. W. Dollof
R. A. Few

P. F. Johnson
D. G. Kumbera
K. Lloyd
P. C. Lyons
L. V. McCall
R. H. Miller
R. W. Nelson

A. F. Parks
N. L. Paulson
J. P. Markey
G. W. Schneider
F. C. Teufel
B. F. Wirtz
J. D. Hopkins

When it approved this standard on March 15, 1979, the IEEE Standards Board had the following membership:

Joseph L. Koepfinger, *Chair*
Irvin N. Howell, Jr, *Vice Chair*
Ivan G. Easton, *Secretary*

G. Y. R. Allen
William E. Andrus
C. N. Berglund
Edward Chellotti
Edward J. Cohen
Warren H. Cook
R. O. Duncan
Jay Forster

Harold S. Goldberg
Richard J. Gowen
H. Mark Grove
Loering M. Johnson
Irving Kolodny
W. R. Kruesi
Leon Levy
J. E. May

Donald T. Michael*
R. L. Pritchard
F. Rosa
Ralph M. Showers
J. W. Skooglund
W. E. Vannah
B. W. Whittington

*Member emeritus

CLAUSE	PAGE
1. Scope	1
2. References	1
3. Service Conditions	2
3.1 Usual Service Conditions	2
3.2 Unusual Service Conditions	2
4. Definitions	3
5. Rating	4
5.1 Rating Information	4
5.2 Rated Maximum Voltage	4
5.3 Rated Frequency	4
5.4 Rated Continuous Current	5
5.5 Rated Minimum Tripping Current (for Series-Trip Reclosers)	12
5.6 Rated Symmetrical Interrupting Current	14
5.7 Rated Symmetrical Making Current	15
5.8 Rated Impulse Withstand Voltage	15
5.9 Rated Control Voltage and Ranges	18
5.10 Rated Cable Charging Interrupting Current (where applicable)	18
6. Design Tests	18
6.1 General	18
6.2 Insulation (Dielectric Tests)	19
6.3 Interruption Tests	20
6.4 Making Current Tests	23
6.5 Minimum Tripping Current Tests	23
6.6 Partial Discharge Tests	24
6.7 Radio Influence Voltage Tests (RIV)	24
6.8 Surge Current Test; Series Coil Reclosers	26
6.9 Temperature Rise Test	26
6.10 Time-Current Tests	28
6.11 Mechanical Operations Tests	29
6.12 Cable Charging Current Interrupting Test	30
6.13 Transformer Magnetizing Current Interruption Test	31
6.14 Control Elements Surge Withstand Capability Tests	32
7. Production Tests	33
7.1 Reclosing and Overcurrent Trip Calibration	34
7.2 Control, Secondary Wiring and Accessory Devices Check Tests	34
7.3 Dielectric Withstand Test; One Minute Dry Low Frequency	34
7.4 Mechanical Operations Tests	34
7.5 Leak Test	34
8. Construction Requirements	34
8.1 Tank Construction; Submersible or Dry Vault Reclosers	34

CLAUSE	PAGE
8.2 Grounding Provisions	35
8.3 Insulating Medium Quantity Indicators (Submersible Reclosers)	35
8.4 Oil Sampling Provisions (Submersible Reclosers)	35
8.5 Manual Operating Provision	35
8.6 Position Indicator	36
8.7 Nameplate Markings	36
8.8 Stored Energy Mechanism Charge Indicator	36
8.9 Safety Provisions	36
8.10 Separate Mounting of Control Apparatus	36
8.11 Counters	37
8.12 Conductor Terminal Sizes	37
8.13 Vacuum Interrupters	37

An American National Standard

IEEE Standard Requirements for Overhead, Pad Mounted, Dry Vault, and Submersible Automatic Circuit Reclosers and Fault Interrupters for AC Systems

1. Scope

This standard applies to all overhead, pad mounted, dry vault and submersible single or multi-pole alternating current automatic circuit reclosers and fault interrupters for rated maximum voltages above 1000 V.

In order to simplify this standard where possible, the term *recloser* has been substituted for *automatic circuit recloser* or *fault interrupter* or both.

2. References

When the following American National Standards and Guides referred to in this standard are superseded by a revision approved by the American National Standards Institute, the latest revision shall be used.

[1] ANSI C37.85-1972 (R1978), Interrupters Used in Power Switchgear, X-Radiation Limits for AC High-Voltage Power Vacuum (includes ANSI C37.85a-1972)¹

[2] ANSI C84.1-1977, Voltage Ratings for Electric Power Systems and Equipment (60 Hz) (includes ANSI C84.1a-1980)

[3] ANSI/IEEE C37.09-1979, Test Procedure for High-Voltage Circuit Breakers Rated on a Symmetrical Current Basis

¹ANSI documents are available from the American National Standard Institute, 1430 Broadway, New York, NY 10018.

[4] ANSI/IEEE C37.100-1981, Definitions for Power Switchgear

[5] ANSI/IEEE Std 386-1977, Separable Insulated Connectors for Power Distribution Systems Above 600 V

[6] IEEE Std 4-1978, Standard Techniques for High-Voltage Testing

[7] NEMA 107-1964 (1976), Methods of Measurement of Radio Influence Voltage (RIV) of High-Voltage Apparatus²

3. Service Conditions

3.1 Usual Service Conditions

Reclosers conforming to this standard shall be suitable for operation at their standard rating provided that:

- 1) The temperature of the cooling air (ambient temperature) is not above 40 °C or below –30 °C.
- 2) The altitude does not exceed 1000 m (3300 ft).
- 3) For submersible units, the water head does not exceed 3 m (10 ft) above the base of the enclosure during occasional submersion. Exposure to chemical or electrochemical reactions may be encountered in a subgrade environment.

3.2 Unusual Service Conditions

3.2.1 Abnormal Ambient Temperatures

Reclosers may be applied at higher or lower ambient temperatures than specified, but performance may be affected and special consideration shall be given to these applications.

3.2.2 Altitudes Above 1000 m (3300 ft)

Reclosers may be applied at altitudes higher than 1000 m (3300 ft). However, the basic impulse insulation level, rated maximum voltage and rated continuous current shall be multiplied individually by the correction factors in Table 1, Columns 3 and 4, to obtain values at which the application may be made. The rated interrupting current, related required capabilities, and rated interrupting time are not affected by altitude.

Reclosers designed for standard temperature rise may be used at normal current rating without exceeding total temperature limits provided that the ambient temperature does not exceed the ambient allowed in 3.1 multiplied by the factor shown in Column 5 of Table 1.

3.2.3 Other Conditions which May Affect Design and Application

Where other unusual conditions exist they should be brought to the attention of those responsible for the manufacture of the equipment. Examples of such conditions are:

²NEMA documents are available from National Electrical Manufacturers Association, Order Department, 2101 L Street, N.W., Washington, DC 20037.

Table 1— Altitude Correction

Altitude Correction Factor to be Applied to				
Meters	Feet	Voltage Rating	Current Rating	Ambient Temperature
(Col 1)	(Col 2)	(Col 3)	(Col 4)	(Col 5)
1000	3300	1.00	1.00	1.00
1200	4000	0.98	0.99	0.99
1500	5000	0.95	0.99	0.98
3000	10 000	0.80	0.96	0.92
4900	16 000	0.63	0.93	0.85

NOTE — Correction factors in Columns 4 and 5 shall not be applied simultaneously.

- 1) Abnormal vibration, shocks or tilting.
- 2) Unusual transportation or storage conditions.
- 3) Unusual operating duty, frequency of operation, inadequate maintenance, special insulation requirements.
- 4) For overhead, pad mounted, and dry vault reclosers: Exposure to damaging fumes or vapors, excessive or abrasive dust, explosive mixtures of dust or gases, salt air, extreme humidity.
- 5) For submersible reclosers: Exposure to tidal water, highly acidic water, water containing abnormal amounts of dissolved road salt or fertilizer, continuous submersion and stray direct currents.

4. Definitions

The definitions of terms contained in this standard or in other American National Standards referred to in this standard, are not intended to embrace all legitimate meanings of the terms. They are applicable only to the subject treated in this standard

unit operation (of a recloser): An interrupting operation followed by a closing operation. The final interruption is also considered one unit operation. (See Fig 1.)

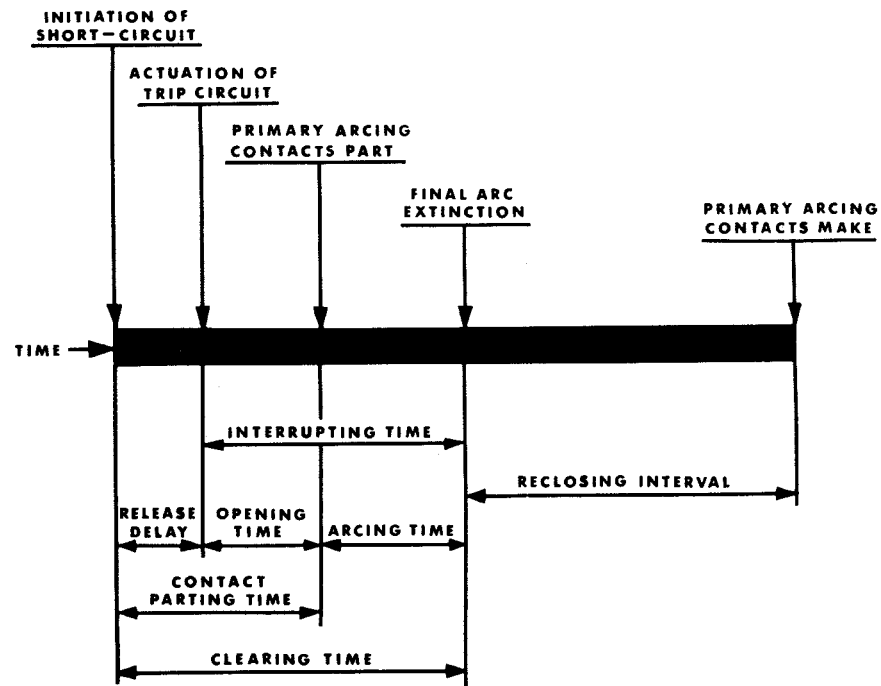

Figure 1— Unit Operation

5. Rating

5.1 Rating Information

The rating shall include the following terms:

- 1) Rated maximum voltage
- 2) Rated frequency
- 3) Rated continuous current
- 4) Rated minimum tripping current (series-trip coil reclosers only)
- 5) Rated symmetrical interrupting current
- 6) Rated symmetrical making current
- 7) Rated impulse withstand voltage
- 8) Rated control voltage
- 9) Rated cable charging interrupting current (where applicable)

5.2 Rated Maximum Voltage

The rated maximum voltage of reclosers shall be the values shown in Column 3 of Tables 2, 4 and 6.

5.3 Rated Frequency

The rated frequency of reclosers shall be 60 Hz.

5.4 Rated Continuous Current

The rated continuous currents of reclosers shall be the values shown in Column 7 of Tables 2, 4 and 6, except as limited by the series coil or minimum trip settings as given in Tables 3, 5 and 7.

5.4.1 Conditions of Continuous Current Rating

- 1) Reclosers shall be used under the usual service conditions defined in 3.1
- 2) Current ratings shall be based on the total temperature limits of the materials used for such parts. A temperature rise reference is given to permit testing at reduced ambient
- 3) Reclosers designed for installation in enclosures shall have their ratings based on the ventilation of such enclosures and a 40 °C ambient temperature outside the enclosure
- 4) Outdoor reclosers and indoor reclosers without enclosures shall have ratings based on a 40 °C ambient temperature

5.4.2 Limits of Observable Temperature Rise

At rated current, the observable hottest-spot temperature rise above ambient and the total temperature of each of the various parts shall not exceed those listed in Table 8.

5.4.2.1

Classification of Insulating Materials: For the purpose of establishing temperature limits, insulating materials shall be classified as follows:

- 1) *Class 90 Insulation:* Materials or combinations of materials such as cotton, silk, and paper without impregnation. Other materials or combinations of materials may be included in this class if, by experience or accepted tests, they can be shown to be capable of operation at 90 °C.
- 2) *Class 105 Insulation:* Materials or combinations of materials such as cotton, silk, and paper when suitably impregnated or coated or when immersed in a dielectric liquid such as oil. Other materials or combinations of materials may be included in this class if, by experience or accepted tests, they can be shown to be capable of operation at 105 °C.
- 3) *Class 130 Insulation:* Materials or combinations of materials such as mica, glass fiber, asbestos, etc, with suitable bonding substances. Other materials or combinations of materials, not necessarily inorganic, may be included in this class if, by experience or accepted tests, they can be shown to be capable of operation at 130 °C.
- 4) *Class 155 Insulation:* Materials or combinations of materials such as mica, glass fiber, asbestos, etc, with suitable bonding substances. Other materials or combinations of materials, not necessarily inorganic, may be included in this class if, by experience or accepted tests, they can be shown to be capable of operation at 155 °C.
- 5) *Class 180 Insulation:* Materials or combinations of materials such as silicone elastomer, mica, glass fiber, asbestos, etc with suitable bonding substances such as appropriate silicone resins. Other materials or combinations of materials may be included in this class if, by experience or accepted tests, they can be shown to be capable of operation at 180 °C.
- 6) *Class 220 Insulation:* Materials or combinations of materials that by experience or accepted tests can be shown to be capable of operation at 220 °C.
- 7) *Over Class 220 Insulation:* Insulation that consists entirely of mica, porcelain, glass, quartz, and similar inorganic materials. Other materials or combinations of materials may be included in this class if, by experience or accepted tests, they can be shown to be capable of operation at temperatures over 220 °C.

Table 2— Rated Maximum Voltage, Rated Continuous Current, Rated Interrupting Current, Rated Impulse Withstand Voltage, and Performance Characteristics of Oil Reclosers

Line No	Nominal System Voltage (kV) rms	Rated Maximum Voltage (kV) rms	Rated Impulse Withstand Voltage (kV) Crest	Low-Frequency Insulation Level Withstand Test* kV rms		Current Ratings, Amperes		Standard Operating Duty						Total Number of Unit Operations
				1 min Dry	10 s Wet	Continuous 60 Hz	Symmetrical Interrupting† at Rated Maximum Volts	Percent of Interrupting Rating						
								15–20		45–55		90–100		
								Minimum X/R	Number of Unit Operations	Minimum X/R	Number of Unit Operations	Minimum X/R	Number of Unit Operations	
Col 1	Col 2	Col 3	Col 4	Col 5	Col 6	Col 7	Col 8	Col 9	Col 10	Col 11	Col 12	Col 13	Col 14	Col 15
Single-Phase Reclosers														
1	14.4	15.0	95	35	30	50	1250	2	40	4	40	8	20	100
2	14.4	15.5	110	50	45	100	2000	2	32	5	24	10	12	68
3	14.4	15.5	110	50	45	280	4000	3	32	6	20	12	12	64
4	14.4	15.5	110	50	45	560	10 000	4	28	8	20	15	10	58
5	24.9	27.0	150	60	50	100	2500	2	32	5	24	12	12	68
6	24.9	27.0	150	60	50	280	4000	3	32	6	20	13	12	64
7	34.5	38.0	150	70	60	560	8000	4	28	8	20	15	10	58
Three-Phase Reclosers														
8	14.4	15.0	95	35	30	50	1250	2	40	4	40	8	20	100
9	14.4	15.5	110	50	45	100	2000	2	32	5	24	10	12	68
10	14.4	15.5	110	50	45	280	4000	3	32	6	20	12	12	64
11	14.4	15.5	110	50	45	400	4000	3	32	6	20	12	12	64

Line No	Nominal System Voltage (kv) rms	Rated Maximum Voltage (kV) rms	Rated Impulse Withstand Voltage (kV) Crest	Low-Frequency Insulation Level Withstand Test* kV rms			Current Ratings, Amperes		Standard Operating Duty					
				1 min Dry	10 s Wet	Continuous 60 Hz	Symmetrical Interrupting† at Rated Maximum Volts	Percent of Interrupting Rating						Total Number of Unit Operations
								15-20		45-55		90-100		
								Minimum X/R	Number of Unit Operations	Minimum X/R	Number of Unit Operations	Minimum X/R	Number of Unit Operations	
Col 1	Col 2	Col 3	Col 4	Col 5	Col 6	Col 7	Col 8	Col 9	Col 10	Col 11	Col 12	Col 13	Col 14	Col 15
12	14.4	15.5	110	50	45	560	8000	3	28	7	20	14	10	58
13	14.4	15.5	110	50	45	560	16 000	4	16	8	8	16	4	28
14	14.4	15.5	110	50	45	560	16 000	4	28	8	20	16	10	58
15	14.4	15.5	110	50	45	1120	16 000	4	28	8	20	16	10	58
16	24.9	27.0	150	60	50	100	2500	2	32	5	24	12	12	68
17	24.9	27.0	150	60	50	560	8000	4	28	8	20	15	10	58
18	24.9	27.0	150	60	50	1120	8000	4	28	8	20	15	10	58
19	24.9	27.0	150	60	50	560	12 000	4	28	8	20	15	10	58
20	34.5	38.0	150	70	60	400	6000	4	28	8	24	15	10	62
21	34.5	38.0	150	70	60	560	16 000	4	28	8	20	15	10	58
22	34.5	38.0	150	70	60	1120	12 000	4	28	8	20	15	10	58
23	46.0	48.3	250	105	95	560	10 000	4	28	8	20	15	10	58
24	69.0	72.5	350	160	140	560	8000	4	28	8	20	16	10	58

*These are performance characteristics specified as test requirements in this standard.
 †See Table 3 for complete data on rated interrupting currents for reclosers using smaller series coil sizes or reduced minimum trip settings.

Table 3— Continuous Current and Interrupting Current Ratings of Oil Reclosers

Continuous Current Rating, (A)	Interrupting Current Rating in Amperes at Rated Maximum Voltage													
	Single-Phase Series Coil Reclosers							Three-Phase Series Coil Reclosers						
	Recloser Line No							Recloser Line No						
	1	2	3	4	5	6	7	8	9	10	11	12–17	16	20
	Rated Maximum Voltage, kV							Rated Maximum Voltage, kV						
	15.0	15.5	15.5	15.5	27.0	27.0	38.0	15.0	15.5	15.5	15.5	15–27	27.0	34.0
5	125	200	—	—	200	—	—	125	200	—	—	—	200	—
10	250	400	—	—	400	—	—	250	400	—	—	—	400	—
15	375	600	—	—	600	—	—	375	600	—	—	—	600	—
25	625	1000	1500	—	1000	—	—	625	1000	1500	1500	—	1000	1500
35	875	1400	2100	—	1400	—	—	875	1400	2100	2100	—	1400	2100
50	1250	2000	3000	—	2000	3000	—	1250	2000	3000	3000	—	2000	3000
70	—	2000	4000	—	2500	4000	—	—	2000	4000	4000	—	2500	4200
100	—	2000	4000	6000	2500	4000	6000	—	2000	4000	4000	6000	2500	6000
140	—	—	4000	8400	—	4000	8000	—	—	4000	4000	8000	—	6000
200	—	—	4000	10 000	—	4000	8000	—	—	4000	4000	8000	—	6000
280	—	—	4000	10 000	—	4000	8000	—	—	4000	4000	8000	—	6000
400	—	—	—	10 000	—	—	8000	—	—	—	4000	8000	—	6000
560	—	—	—	10 000	—	—	8000	—	—	—	—	8000	—	—

Minimum Trip Setting, (A)	Three-Phase Non-Series Coil Reclosers Recloser Line No												
	11	12	13	14	15	17	18	19	20	21	22	23	24
	Rated Maximum Voltage, kV												
	15.5	15.5	15.5	15.5	15.5	27.0	27.0	27.0	38.0	38.0	38.0	48.3	72.5
100	3000	—	—	—	—	—	—	—	3000	3000	—	3000	3000
140	4000	—	—	—	—	—	—	—	4200	4200	—	4200	4200
200	4000	6000	6000	6000	—	6000	6000	6000	6000	6000	6000	6000	6000
280	4000	8000	8400	8400	—	8000	8000	8400	6000	8400	8400	8400	8000
400	4000	8000	12 000	12 000	12 000	8000	8000	12 000	6000	12 000	12 000	10 000	8000
560	4000	8000	16 000	16 000	16 000	8000	8000	12 000	6000	16 000	12 000	10 000	8000
800	4000	8000	16 000	16 000	16 000	8000	8000	12 000	6000	16 000	12 000	10 000	8000
1120	—	8000	16 000	16 000	16 000	8000	8000	12 000	—	16 000	12 000	10 000	8000
1600	—	—	—	—	16 000	—	8000	—	—	—	12 000	—	—
2240	—	—	—	—	16 000	—	8000	—	—	—	12 000	—	—

NOTE — For interrupting current ratings at other than rated voltage, consult the manufacturer. The interrupting current ratings of reclosers are not generally on a constant kVA basis.

Table 4— Rated Maximum Voltage, Rated Continuous Current, Rated Interrupting Current, Rated Impulse Withstand Voltage, and Performance Characteristics of Reclosers with Vacuum Interrupters

Line No	Nominal System Voltage, kV rms	Rated Maximum Voltage, kV rms	Rated Impulse Withstand Voltage, kV Crest	Low-Frequency Insulation Level Withstand Test* kV rms			Current Ratings (A)		Standard Operating Duty					
				1 min Dry	10 s Wet	Con- tinuous, 60 Hz	Symmet- rical Inter- rupting† at Rated Maximum Volts	Percent of Interrupting Rating						Total Num- ber of Unit Oper- ations
								15–20		45–55		90–100		
				Mini- mum X/R	Number of Unit Operations	Mini- mum X/R	Number of Oper- ations	Mini- mum X/R	Number of Oper- ations					
Col 1	Col 2	Col 3	Col 4	Col 5	Col 6	Col 7	Col 8	Col 9	Col 10	Col 11	Col 12	Col 13	Col 14	Col 15
Single-Phase Reclosers														
1	14.4	15.5	110	50	45	200	2000	2	52	5	68	10	18	138
Three-Phase Reclosers														
2	14.4	15.5	110	50	45	200	2000	2	52	5	68	10	18	138
3	14.4	15.5	110	50	45	400	6000	3	48	7	60	14	16	124
4	14.4	15.5	110	50	45	560	12 000	4	44	8	66	15	16	116
5	14.4	15.5	110	50	45	800	12 000	4	44	8	56	15	16	116
6	14.4	15.5	110	50	45	560	16 000	4	44	8	52	16	16	112
7	14.4	15.5	110	50	45	800	16 000	4	44	8	52	16	16	112
8‡	14.4	15.5	110	50	45	1120	16 000	4	44	8	52	16	16	112
9	24.9	27.0	125	60	50	560	10 000	3	44	7	56	14	16	116
10	34.5	38.0	150	70	60	560	12 000	4	44	8	56	15	16	116

NOTE — The Standard operating duty represents half life as measured by contact erosion. Refer to the manufacturer's method for determining permissible contact erosion.

*These are performance characteristics specified as test requirements in this standard.

†See Table 5 for complete data on rated interrupting currents for reclosers using smaller series coil sizes or reduced minimum trip settings.

‡These lines have been approved as Suggested Standard for Future Design.

Table 5— Continuous Current and Interrupting Current Ratings of Reclosers with Vacuum Interrupters

Continuous Current Rating, Amperes	Interrupting Current Rating in Amperes at Rated Maximum Voltage				
	Single-Phase Series Coil Reclosers		Three-Phase Series Coil Reclosers		
	Recloser Line No		Recloser Line No		
	1		2	4	9
	Rated Maximum Voltage, kV		Rated Maximum Voltage, kV		
	15.5		15.5	15.5	27.0
5	200		200	—	—
10	400		400	—	—
15	600		600	—	—
25	1000		1000	—	—
35	1400		1400	—	—
50	2000		2000	3000	3000
70	2000		2000	4200	4200
100	2000		2000	6000	6000
140	2000		2000	8400	8400
200	2000		2000	12 000	10 000
280	—		—	12 000	10 000
400	—		—	12 000	10 000
560	—		—	12 000	10 000

Minimum Trip Setting, Amperes	Three-Phase Nonseries Coil Reclosers							
	Recloser Line No							
	3	4	5	6	7	8	9	10
	Rated Maximum Voltage, kV							
	15.5	15.5	15.5	15.5	15.5	15.5	27.0	38.0
100	3000	3000	3000	3000	—	—	3000	3000
140	4200	4200	4200	4200	—	—	4200	4200
200	6000	6000	6000	6000	—	—	6000	6000
280	6000	8400	8400	8400	—	—	8400	8400
400	6000	12 000	12 000	12 000	12 000	12 000	10 000	12 000
500	6000	12 000	12 000	16 000	16 000	16 000	10 000	12 000
800	6000	12 000	12 000	16 000	16 000	16 000	10 000	12 000
1120	—	12 000	12 000	16 000	16 000	16 000	10 000	12 000
1600	—	—	12 000	—	16 000	16 000	—	—
2240	—	—	—	—	16 000	—	—	—

NOTE — For interrupting current ratings at other than rated voltage, consult the manufacturer. The interrupting current ratings of reclosers are not generally on a constant kVA basis.

NOTES:

- 1 — Insulation is considered to be *impregnated* when a suitable substance provides a bond between components of the structure and also a degree of filling or surface-coverage sufficient to give adequate performance

under the extremes of temperature, surface contamination (moisture, dirt, etc), and mechanical stress expected in service. The impregnant must not flow or deteriorate enough at operating temperature so as to seriously affect performance in service.
- 2 — The electrical and mechanical properties of the insulation must not be impaired by the prolonged application of the limiting insulation temperature permitted for the insulation class. The word *impaired* is here used in the sense of causing any change that could disqualify the insulating material from continuously performing its intended function, whether it is creepage spacing, mechanical support, or dielectric barrier action.
- 3 — In the preceding definitions, the words *accepted tests* are intended to refer to recognized test procedures established for the thermal evaluation of materials by themselves or in simple combinations. Experience or test data, used in classifying insulating materials, are distinct from the experience or test data derived for the use of materials in complete insulation systems. The thermal endurance of complete systems may be determined by test procedures specified by the responsible technical committees. A material that is classified as suitable for a given temperature in the preceding may be found suitable for a different temperature, either higher or lower, by an insulation system test procedure. For example, it has been found that some materials suitable for operation at one temperature in air may be suitable for a higher temperature when used in a system operated in an inert gas atmosphere.
- 4 — It is important to recognize that other characteristics, in addition to thermal endurance, such as mechanical strength and moisture resistance, are required in varying degrees in different applications for the successful use of insulating materials.

5.5 Rated Minimum Tripping Current (for Series-Trip Reclosers)

The rated minimum tripping current shall be twice the continuous current rating with a tolerance of $\pm 10\%$.

NOTE — The minimum tripping current for shunt trip reclosers is variable and has no relation to the rated continuous current. Information on specific reclosers should be obtained from the manufacturer.

Table 6— Rated Maximum Voltage, Rated Continuous Current, Rated Interrupting Current, Rated Impulse Withstand Voltage and Performance Characteristics of Pad Mounted, Dry Vault and Submersible Reclosers, and Non-Reclosing Fault Interrupters, All with Vacuum Interrupters

Line No	Nominal System Voltage kV rms	Rated Maximum Voltage kV rms	Rated Impulse Withstand Voltage kV Crest	Low-Frequency Insulation Level Withstand Test* kV rms		Current Ratings, (A)		Standard Operating Duty†							Total Number of Operations	Withstand Test Voltage kV — dc 15 min
				1 min Dry	10 s Wet	Maximum Continuous, 60 Hz	Symmetrical Interrupting at Rated Maximum V	Percent of Interrupting Rating								
								15–20	45–55	90–100	Minimum X/R	Number of Unit Operations	Minimum X/R	Number of Unit Operations		
Col 1	Col 2	Col 3	Col 4	Col 5	Col 6	Col 7	Col 8	Col 9	Col 10	Col 11	Col 12	Col 13	Col 14	Col 15	Col 16	
Three-Phase Reclosers																
SSFD 1	14.4	15.5	95	35		200	8000	1	44	2	56	4	16	116	53	
SSFD 2	14.4	15.5	95	35		560	6000	3	48	7	60	14	16	124	53	
3	14.4	15.5	95	35		560	12 000	4	44	8	56	15	16	116	53	
SSFD 4	14.4	15.5	95	35		560	12 000	1	44	2	52	4	16	112	53	
SSFD 5	24.9	27.0	125	40		200	16 000	1	44	2	52	4	16	112	78	
6	24.9	27.0	125	40		560	10 000	3	28	7	20	14	10	58	78	

NOTE — This standard operating duty represents half life as measured by contact erosion. Refer to manufacturer’s methods for determining permissible contact erosion.

*See Table 7 for complete data on rated interrupting currents for reclosers using smaller series coil sizes or reduced minimum trip settings.

†These are performance characteristics specified as test requirements in this standard.

Table 7— Continuous Current and Interrupting Current Ratings of Pad Mounted, Dry Vault and Submersible Reclosers, and Non-Reclosing Fault Interrupters, All with Vacuum Interrupters

		Interrupting Current Rating in Amperes at Rated Maximum Voltage					
		Three-Phase Series Coil Reclosers					
		Recloser Line No					
		1	2	3	4	5	6
Continuous Current Rating, (A)	Rated Maximum Voltage, (kV)						
	15.5			27.0			
50				3000			3000
70				4200			4200
100				6000			6000
140				8400			8400
200				12 000			10 000
280				12 000			10 000
400				12 000			10 000
560				12 000			10 000

		Three-Phase Non-Series Coil Reclosers					
		Recloser Line No					
		1	2	3	4	5	6
Minimum Trip Setting, (A)	Rated Maximum Voltage, (kV)						
	15.5	15.5	15.5	15.5	27.0	27.0	
100	6000	6000		3000	3000	3000	3000
140	8000	3000		4200	4200	4200	4200
200	8000	4200		6000	6000	6000	6000
280	8000	6000		8400	8400	8400	8400
400	8000	6000		12 000	12 000	12 000	10 000
560		6000		12 000	16 000	16 000	10 000
800		6000		12 000	16 000	16 000	10 000
1120		6000		12 000	16 000	16 000	10 000

5.6 Rated Symmetrical Interrupting Current

The rated symmetrical interrupting currents of reclosers shall be as given in Column 8 of Tables 2, 4 and 6, except as limited by the series coil or minimum trip settings as given in Tables 3, 5 and 7.

The rated symmetrical interrupting current shall be based on the capability of the reclosers to interrupt the corresponding asymmetrical current in circuits having X/R values³ as given in Columns 9, 11 and 13 of Tables 2, 4 and 6 and with a normal frequency recovery voltage equal to the rated maximum voltage.

The rms value of asymmetrical fault current, at any time after initiation of the fault, is dependent upon the instantaneous voltage existing at the moment the fault is initiated and upon the decrement of the direct-current component which is determined by the X/R value of the circuit. The following multiplying factors shall be used to obtain the maximum rms value of asymmetrical current at one-half cycle corresponding to the rated symmetrical interrupting current.

X/R	Multiplying Factor
8	1.39
10	1.44
12	1.48
14	1.51
16	1.53

5.7 Rated Symmetrical Making Current

The rated symmetrical making current shall be the same value as the rated symmetrical interrupting current, with maximum asymmetry corresponding to the X/R ratio.

5.8 Rated Impulse Withstand Voltage

The rated impulse withstand voltage of reclosers shall be as given in Column 4 of Tables 2, 4 and 6 and shall be negative or positive, depending upon which gives the lower insulation strength. The voltage wave shall reach its crest value in 1.2 μ s and decay to one-half its crest value in 50 μ s.

³ X/R is the ratio of inductive reactance to resistance of a circuit at rated frequency. X_1/R_1 is to be used for three-phase faults and $\frac{2X_1 + X_0}{2R_1 + R_0}$ is to be used for phase-to-ground faults.

Table 8— Limits of Observable Temperature Rise

Contacts, Conducting Joints, or Bushing Terminals when Clean and Bright	Limit of Observable Hottest Spot Temperature Rise (°C)	Total Temperature (°C)
Coils and Their Terminals		
Class 90 Insulation	50	90
Class 105 Insulation	65	105
Class 130 Insulation	90	130
Class 155 Insulation	115	155
Class 180 Insulation	140	180
Class 220 Insulation	180	220
Series coils with over 220 class insulation, or bare	No Limit	No Limit
Recloser Contacts Conducting Joints and Other Parts *		
Silver to silver in air	65	105
Silver to silver in air — vacuum interrupter studs/clamps	85	125
Silver to silver in oil	50	90
Copper to copper in air	50	90
Copper to copper in oil	30	70
Copper to aluminum in air	50	90
Copper to aluminum in oil	30	70
Oil 2.5 cm (1 in) Below Surface (Top Oil)	45	85
Terminal Connections[†]		
Silver to silver	65	105
Copper to copper	50	90
Copper to aluminum	50	90

*Contacts or other parts in other than oil or air may be operated at other temperatures providing it can be shown by experience or tests that accelerated deterioration will not occur.

†If connections are made to cables, recognition must be given to possible thermal limitations of cable and appropriate measures taken.

Table 9— Rated Control Voltage and Ranges

Direct Current (1) Control Voltage Ranges (4), (5)		
Nominal Voltage	Closing and Auxiliary Functions	Tripping Functions
24 (2)	—	14 – 28 (6)
48 (2)	38 – 56	28 – 56 (6)
125	100 – 140	70 – 140
250	200 – 280	140 – 280

Alternating Current Control Voltage Ranges (3), (4), (5)	
Nominal Voltage (60 Hz)	Closing, Tripping and Auxiliary Functions
Single Phase	
120	104 – 127 (3)
240	208 – 254 (3)
480	416 – 508 (3)
Polyphase	
208Y/120	180Y/104 – 220Y/127
240	208 – 254
480	416 – 508
480Y/277	416Y/240 – 508Y/292

NOTES:

- 1 — It is recommended that the coils of closing, auxiliary and tripping devices which are directly connected continually to one dc potential should be connected to the negative control bus so as to minimize electrolytic deterioration.
- 2 — 24 V or 48 V tripping, closing, and auxiliary functions are recommended only when the device is located near the battery or where special effort is made to insure the adequacy of conductors between battery and control terminals. 24 V as the primary closing source is not recommended. It is suitable for operation of the auxiliary functions such as relays and contactors.
- 3 — Includes heater circuits.
- 4 — Relays, motors, and other auxiliary equipment which function as a part of the control for a device shall be subject to the voltage limits imposed by this standard, whether mounted at the device or at a remote location.
- 5 — Reclosers in some applications may be exposed to control voltages exceeding those specified here due to abnormal conditions such as abrupt changes in line loading. Such applications require specific study, and the manufacturer should be consulted. Also, applications of reclosers containing solid-state control exposed continuously to control voltages approaching the upper limits of ranges specified herein require specific attention and the manufacturer should be consulted before application is made.
- 6 — Reclosers having self-contained dc control sources shall operate over the range of 85% to 115% of nominal voltage, and Table 5 shall not apply.

Table 10— Cable Charging Interrupting Current Ratings

Rated Maximum Line Voltage (kV)	Cable Charging Current RMS Amperes	
	Overhead	Pad Mounted and Submersible
15.5	2	10
27	5	25
38	5	40

5.9 Rated Control Voltage and Ranges

When measured at the control power terminals of the operating mechanisms with the maximum operating current flowing, nominal voltages and their permissible ranges for the control power supply of switching and interrupting devices shall be as shown in Table 9.

5.10 Rated Cable Charging Interrupting Current (where applicable)

The cable charging interrupting current ratings for reclosers having this capability are as given in Table 10.

6. Design Tests

Reclosers shall be capable of meeting the design tests described in 6.2 through 6.14 inclusive. Once made, the design tests need not be repeated unless the design is changed so as to modify the performance characteristics of the recloser.

6.1 General

6.1.1 Condition of Device to be Tested

The recloser shall be new and in good condition, and tests shall be applied before the device is put into commercial use.

6.1.2 Mounting of Device

The recloser shall be mounted in a manner closely approximating the normal service conditions for which it is designed. If the recloser normally requires control apparatus, the control apparatus shall be connected during the tests.

6.1.3 Grounding of Device

All groundable parts of the recloser, and control apparatus where used, shall be grounded by a lead attached to the ground terminal and other groundable parts in a manner not to decrease the withstand voltage.

6.1.4 Frequency

The frequency of the supply voltage shall be 60 Hz \pm 5%. A sine wave of acceptable commercial standards shall be applied.

6.1.5 Control Voltage

The recloser shall perform satisfactorily over the full range of control voltages specified in 5.9.

6.2 Insulation (Dielectric Tests)

Reclosers shall be capable of withstanding, without damage to the recloser and associated control apparatus, if any, the following test voltages when tested in accordance with 6.1 and as follows:

6.2.1 Withstand Test Voltages

- 1) Impulse withstand test voltage shall be a $1.2 \cdot 50 \mu\text{s}$ voltage impulse, with a crest value as given in Column 4 of Tables 2, 4 and 6. At least three positive and three negative impulses shall be applied to the test device. If flashover occurs on only one test during any group of three consecutive tests, three more tests shall be made. If the recloser successfully withstands all three of the second group of tests, the flashover in the first group shall be considered a random flashover and the recloser shall be considered as having successfully passed the test. If an additional flashover occurs the recloser shall be considered to have failed. The following tolerances shall apply during these tests, unless otherwise specified.
 - a) *Design Tests.* Reclosers shall pass a full wave $1.2 \cdot 50 \mu\text{s}$ voltage impulse with a virtual front time based on the rated full wave impulse voltage equal to or less than $1.2 \mu\text{s}$ with a crest voltage equal to or exceeding the crest value given in Column 4 of Tables 2, 4 and 6, and with a time to the 50% value of the crest voltage equal to or greater than $50 \mu\text{s}$.
 - b) *Conformance Tests.* When impulse voltage tests are required for conformance tests, reclosers shall be capable of passing a $1.2 \cdot 50 \mu\text{s}$ full wave impulse voltage test series with values as specified by the purchaser in accordance with the following: a virtual front time, based on the rated full wave impulse voltage, equal to or greater than $1.2 \mu\text{s}$; a crest voltage not exceeding the rated full wave impulse withstand voltage; and a time to the 50% value of the crest voltage not exceeding $50 \mu\text{s}$.
NOTE — When the interrupting medium is vacuum, the recloser shall withstand the rated impulse voltage in the closed position. However, the unique characteristics of an open vacuum interrupter or vacuum gap make it permissible to have random sparkovers of the open vacuum interrupter as much as 25% below the rated impulse withstand voltage of the recloser. If such an impulse surge sparks over the open interrupter contacts, the impulse current will pass through the open contacts without damage to the interrupter unit. An impulse sparkover of the open vacuum contacts may be followed by a flow of power current which will be interrupted without damage to the recloser.
- 2) Low frequency withstand test voltages shall be applied with a crest value equal to 1.414 times the rated low-frequency withstand dry and wet test values given in Columns 5 and 6 of Tables 2, 4 and 6 with test durations of 60 s for the dry test and 10 s for the wet test. Wet tests shall be made in accordance with IEEE Std 4–1978 [6].⁴ If bushing coordination gaps are used, they shall be retained in place during tests and shall withstand these test voltages. Wet tests shall not apply to reclosers utilizing submersible cables and terminations.
- 3) On reclosers using submersible cable connectors a dc withstand test shall be used in addition to the low-frequency withstand test in (2) above. When used, the test voltage applied shall be the value given in Column 16 of Table 6.

6.2.2 Electrical Connections

- 1) On overhead reclosers electrical connections shall be made by means of bare wire, inserted in each terminal. These bare wires shall project in such a manner as not to decrease the withstand value. Any necessary bends may be made at the terminals. The test lead connections shall be made to the wires projecting from the terminals.
- 2) On pad mounted, submersible and dry vault reclosers connections shall be made through a cable termination similar to that for which the recloser was designed. If terminations capable of meeting the specified dielectric

⁴The numbers in brackets correspond to the references listed in Section 2 of this standard.

voltage are not available, other terminations (bushing or connectors, or both) may be substituted for the purpose of performing these tests.

6.2.3 Points of Application of Test Voltage

Tests 1, 2, and 3 shall be made on multi-pole reclosers. Tests 1 and 2 shall be made on single pole reclosers.

Test 1: With the recloser closed, and with tanks and groundable parts grounded, the test voltage shall be applied simultaneously to all of the terminals on one side of the recloser.

Test 2: With the recloser open, the test voltage shall be applied simultaneously to the terminals on one side of the recloser. The other terminals, tanks and groundable parts shall be grounded. Then, reverse connections and repeat procedure.

Test 3: With the recloser closed, the test voltage shall be applied to the middle phase of the recloser. The terminals of the other phase, all tanks and groundable parts shall be grounded.

6.2.4 Temperature

Dielectric tests shall be made at the temperature attained under the conditions of commercial testing.

6.2.5 Dielectric Test Procedures and Voltage Measurements

The dielectric test procedures and the methods of voltage measurement shall be in accordance with IEEE Std 4-1978 [6].

6.3 Interruption Tests

If three-phase tests are made, when testing reclosers intended for applications on multi-grounded wye (**Y**) systems, both the source and load neutrals shall be grounded for one fourth of the unit operations specified in Column 10 of Tables 2, 4 and 6. Otherwise for three phase tests, either the load neutral or the supply shall be grounded, but not both. If single-phase tests are made, a ground shall be placed on the test circuit. When single-phase testing is used for proof of three-phase performance, the test voltage shall be 87% of the corresponding phase-to-phase voltage; opening and closing speeds shall be maintained at levels comparable to those obtained during a corresponding three-phase test. Consideration should also be given to the possibility of flashover between phases during actual three-phase operation where ionized gases can communicate. This condition could be simulated on single-phase tests with the addition of temporary ground screens or barriers.

6.3.1 Interrupting Performance (Automatic Operation)

Reclosers when tested according to 6.1 shall be capable of interrupting, automatically, all currents from a value equal to the lowest minimum trip setting up to and including the rated interrupting currents shown in Tables 2, 4 and 6. Also, reclosers, when tested as follows, shall be capable of interrupting, automatically, all currents from a value equal to the lowest minimum trip setting up to and including the rated interrupting currents shown in Tables 2, 4 and 6.

- 1) At any degree of asymmetry corresponding to the X/R values given in Columns 9, 11 and 13 of Tables 2, 4 and 6. For currents other than tabulated, the minimum X/R values shall be determined by interpolation or extrapolation.
- 2) At a test voltage such that the normal frequency recovery voltage is at least:
 - a) For single-phase reclosers, the rated maximum voltage
 - b) For three-phase tests on three-phase reclosers, the rated maximum voltage
 - c) For single-phase tests to prove three-phase performance on three-phase reclosers 87% of the rated maximum voltage

- 3) At the minimum control voltage for which a shunt-trip recloser is designed
- 4) With either terminal connected to the line conductor unless the line and load terminals are identified on the device

6.3.2 Interrupting Performance (Non-Automatic Operation)

Reclosers, when tested according to 6.1 and as follows, shall be capable of interrupting all load currents up to and including the rated continuous current shown in Tables 2, 4 and 6.

The normal frequency recovery voltage shall be the same as specified in 6.3.1 (2).

6.3.2.1 Test Conditions

The power factor of the test circuit shall be equal to or less than 70% lagging. The test circuit shall consist of at least 10% series resistance and inductive reactance having an X/R ratio of 2.0 or more, with the remaining impedance consisting of parallel connected resistance and inductive reactance, as shown in Fig 2(a) or 2(b).

6.3.2.2 Test Procedure

Power shall be applied to the recloser in the closed position. After the closing transient has subsided, the recloser shall be opened by means of the manual operating handle, or by means of the shunt-trip coil if the recloser is so equipped.

Representative oscillographic records shall be obtained of the device performance on each different test circuit.

6.3.3 Determination of Rated Interrupting Current

The operating duty test as specified in 6.3.4 shall be the basis for determination of the rated interrupting current provided all requirements of 6.3.1 are fulfilled and at least two interruptions are performed with the initial current loop having maximum asymmetry as determined by the appropriate multiplying factor in 5.6 for the X/R value in Column 13 of Tables 2, 4 and 6. If two such interruptions are not obtained in the operating duty tests, additional tests as specified in 6.3.1 shall be made but not necessarily on the same recloser.

The operating duty test for three-phase reclosers with contacts ganged for essentially simultaneous opening may be demonstrated by single-phase tests. To prove interrupting performance in accordance with 6.3.1, at least one-fourth of the unit operations given in each of Columns 10, 12 and 14 of Tables 2, 4 and 6 shall be made at 87% of rated maximum voltage as given in Column 3 of Tables 2, 4 and 6. The tests at maximum interrupting current shall include at least one sequence of the maximum number of operations to lockout permissible as described in 6.3.4.1 and 6.3.4.2. The balance of the unit operations may be made at 58% of rated maximum voltage with at least one phase having an initial loop at rated making current as specified by 5.7.

6.3.4 Operating Duty Test

6.3.4.1 Test Conditions

The operating duty test shall consist of the total number of unit operations as given in Column 15 of Tables 2, 4 and 6 and as apportioned in Columns 10, 12 and 14 of Tables 2, 4 and 6 without maintenance during the test.

For the operations required in Column 14 of Tables 2, 4 and 6, at least one fast opening followed by one time-delayed opening shall be at current not less than rated symmetrical interrupting current.

The recloser shall be adjusted to give the maximum permissible number of unit operations, including at least one fast and time-delayed opening, before the lockout operation occurs. If the reclosing intervals are adjustable, these shall be set for the minimum reclosing intervals for which the recloser is designed.

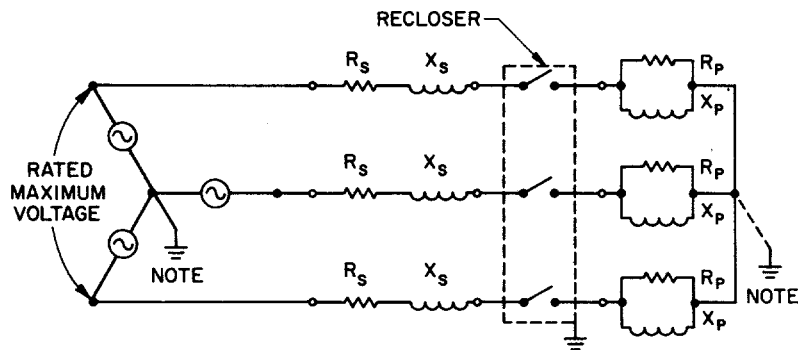

NOTE: Neutral connections are to be made as stated in 6.3.

(a)

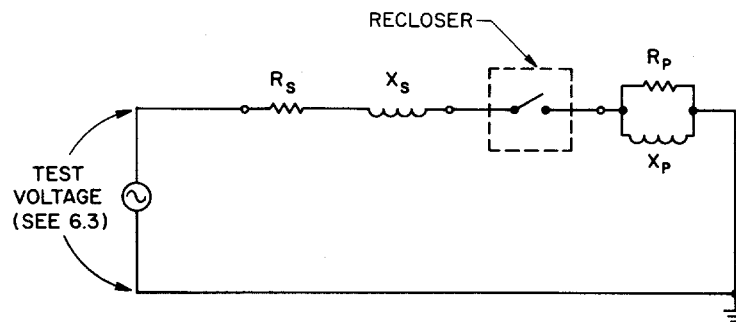

(b)

Figure 2— Test Circuits(a) Three Phase (b) Single Phase

The X/R ratio of the test circuit shall not be less than that given in Columns 9, 11 or 13 of Tables 2, 4 and 6.

The normal frequency recovery voltage shall not fall below the nominal system voltages as given in Column 2 of Tables 2, 4 and 6, and shall be held for one second after final interruption. The oscillograph record showing all pertinent information may be discontinued 100 ms after the final interruption.

6.3.4.2 Test Procedure

Power shall be applied to the recloser when in the closed position and then the recloser shall open and reclose until the lockout position is reached. This series of operations shall be repeated a sufficient number of times to obtain the number of unit operations specified in Columns 10, 12 and 14 of Tables 2, 4 and 6.

Power initiation for each series of operations to lockout shall be timed to produce maximum offset⁵ in the first loop of current with random timing permissible on subsequent closings of each series.

⁵Maximum offset in the first loop shall be considered obtained in a circuit with the specified short circuit power factor or X/R ratio if power is initiated at voltage zero with an allowable deviation of ± 10 electrical degrees.

Oscillograph records shall be obtained of each series of operations. The initial loop of current of each series shall show maximum offset within a limit of +0 and -10%. The current for all unit operations shall be within the range specified in Tables 2, 4 and 6. Current shall be measured at the instant of contact separation for each unit operation.

The current and normal frequency recovery voltages shall be calculated in accordance with ANSI/IEEE C37.09-1979 [3].

6.3.4.3 Condition of Recloser Following Operating Duty Tests

At the end of the standard operating duty test the recloser shall be in the following condition:

- 1) *Mechanical*. The recloser shall be substantially in the same mechanical condition as at the beginning. The recloser shall be capable of automatic and manual operation.
- 2) *Electrical*. The recloser shall be capable of withstanding maximum rated voltage in the open position, and of carrying rated continuous current at rated maximum voltage in the closed position, but not necessarily without exceeding rated temperature rise.

6.3.4.4 Interpretation of Operating Duty Tests

After the standard operating duty tests, it is not to be inferred that the recloser can meet its interrupting rating without inspection and maintenance.

6.3.5 Operating Duty Test; Non-Reclosing Fault Interrupters

The operating duty test shall consist of the total number of operations as given in Column 15 of Table 6, and as apportioned in Columns 10, 12 and 14 of Table 6 without maintenance during the test. One third of the operations shall be performed on a *close-open* operating sequence. Closing may be random except that at least one maximum offset⁶ in the first loop of current at a current equal to the rated symmetrical interrupting current shall occur.

6.4 Making Current Tests

The operating duty tests in 6.3.4 and 6.3.5 shall provide proof of the ability to close and latch on the rated interrupting current of the recloser.

6.5 Minimum Tripping Current Tests

Reclosers shall meet the rated minimum tripping current within the specified limits of $\pm 10\%$ when tested as specified in 6.1 and as follows:

6.5.1 Test Circuit

The recloser shall be connected to a low-voltage power source of alternating current in series with a means for raising the voltage across the recloser.

6.5.2 Test Procedures

With the recloser set for an instantaneous trip, apply a voltage across the recloser that will cause any value less than 80% of the anticipated minimum tripping current to flow and raise the current quickly to the 80% value. Then raise the current slowly at a rate requiring at least 10 s to reach the nominal minimum tripping current. Continue increasing the

⁶Maximum offset in the first loop shall be considered obtained in a circuit with the specific short-circuit power factor or X/R ratio if power is initiated at voltage zero with an allowable deviation of ± 10 electrical degrees.

current at the same rate until the recloser operates, as indicated by the cessation of current. Read the maximum current reached on the ammeter.

6.6 Partial Discharge Tests

This section is presently under study by the Committee, and, when completed, will be published as a supplement.

6.7 Radio Influence Voltage Tests (RIV)

When the primary conductor insulation consists of self restoring dielectric such as porcelain, oil, or gas (including air) the RIV test shall be made if the partial discharge test is not made. Reclosers shall meet the RIV limits when tested in accordance with 6.1 and as follows.

6.7.1 Test Voltages and Limits

The test voltages and limits of conducted radio influence voltage when tested at 1000 kHz shall be as specified in Table 11.

Table 11— Test Voltages and Limits of Conducted Radio Influence Voltage

Rated Maximum voltage (kV)	60 Hz Test Voltage (kV)	Limit of Radio Influence Voltage (μV at 1.0 MHz)
15.0 – 15.5	9.4	500
27.0	16.4	650
38.0	23.0	650
48.3	29.3	650
72.5	44.0	1250

NOTES:

- 1 — In the case of reclosers having voltage ratings not covered by this table, the test shall be made at 105% of the line to neutral voltage, based on the rated maximum voltage.
- 2 — Reclosers having two or more voltage ratings shall be tested on the basis of the highest voltage rating given on the nameplate.

6.7.2 Test Conditions

6.7.2.1 Proximity of Other Apparatus

Any grounded or ungrounded object or structure (except mounting structure when required) shall not be nearer any part of the recloser or its terminals undergoing test than three times the longest overall dimension of the test piece with a minimum allowable spacing of 1 m (3 ft).

Where space requirements under test conditions do not permit the above clearances to be maintained, the test shall be considered as satisfactory if the limits of radio influence voltage obtained are equal to or less than those specified in 6.7.1. In such cases a record should be made of the object, structures, etc and their distances from the recloser under test; these data are to be kept for future use.

6.7.2.2 Oil Filled Reclosers

The tanks of oil-filled reclosers shall be filled with the prescribed amount of oil.

6.7.2.3 Electrical Connections

Conductors of the largest size intended for use with the recloser under test shall be connected to each terminal. The length of the conductors, when used, shall be equal to or greater than the longest overall dimension of the recloser except that the length need not exceed 1.8 m (6 ft). The free end of any such conductor shall terminate in a sphere having a diameter of twice the diameter of the conductor $\pm 10\%$ or shall be shielded in some other suitable manner to eliminate the effect of the end of the conductor as a source of radio influence voltage.

6.7.2.4 Ambient Radio Noise

Tests may be made under conditions prevailing at the time and place of test. However, it is recommended that tests be avoided when the radio influence voltage of the test equipment (including the influence voltage of irrelevant electrical devices) exceeds 50% of the radio influence voltage of the recloser to be tested.

6.7.2.5 Atmospheric Conditions

Tests shall be conducted under atmospheric conditions prevailing at the time and place of test but it is recommended that tests be avoided when the vapor pressure is below 0.67 kPa of mercury (0.2 in) or above 2.02 kPa of mercury (0.6 in).

Since the effects of humidity and air density upon radio influence voltage are not definitely known, no correction factors are recommended for either at the present time. However, it is recommended that barometric pressure and dry and wet bulb thermometer readings be recorded so that, if suitable correction factors should be determined, they could be applied to previous measurements.

6.7.3 Test Equipment and Procedure

The equipment and general method used in making radio influence voltage tests shall be in accordance with the recommendations of NEMA 107-1964 [7].

6.7.3.1 Procedure

Tests shall be made with the recloser in the closed and open positions.

When tests are made with the recloser in the open position, the radio influence voltage shall be determined with the pole or group of poles not connected to the measuring apparatus both grounded and ungrounded.

6.7.3.2 Tests on Multi-Pole Devices

In the case of multi-pole reclosers, one pole or terminal or groups of the same may be tested at one time.

6.7.3.3 Tests on Assembled Apparatus

In the case of assembled equipment, the test shall be made without removing any component part, and the test voltage shall be determined by the component part with the lowest rated voltage. The limiting radio influence voltage shall be identical with the highest value fixed for any of the component parts which determine the test voltage.

6.7.3.4 Precautions

The following precautions shall be observed when making radio influence voltage tests:

- 1) The recloser should be approximately the same temperature as the room in which the tests are made
- 2) The recloser should be dry and clean
- 3) The recloser should not have been subjected to dielectric tests within 2 h prior to the radio influence voltage tests
- 4) In some cases it may be found that the radio influence voltage falls off after the 60 Hz voltage has been applied for a short time. In such cases, it may be desirable to pre-excite the recloser at normal operating voltage for a period not exceeding 5 min before proceeding with the tests

6.8 Surge Current Test; Series Coil Reclosers

Series coil reclosers shall be capable of withstanding two current surges of 65,000 A crest having a $5 \cdot 10 \mu\text{s}$ waveshape.

6.8.1 Test Conditions

If a coil bypass device is required, it shall be mounted in the recloser in the same manner as furnished for normal service. The leads from the high-current impulse generator shall be connected to the terminals of the recloser.

6.8.2 Test Procedure

Two current surges of the specified current value shall be applied to each phase.

Following this test the recloser shall be tested at the minimum tripping current so as to cause it to go through one automatic operation to lockout.

6.8.3 Condition After Test

At the end of the test the recloser, and the coil bypass device if used, shall be in the following condition:

- 1) *Mechanical.* Substantially in the same mechanical condition as at the beginning except for minor arc scars on any gap electrodes of the coil bypass device. There shall be no indication of external flashover of the coil bypass device, from the terminals of the coil bypass device to any other parts of the recloser or of the series coil of the recloser.
- 2) *Electrical.* The recloser in the open position and with the coil bypass device, if used, connected in its normal operating position shall be capable of withstanding rated maximum voltage and when in the closed position, of functioning correctly on overcurrent to go through its cycle to lockout.

6.9 Temperature Rise Test

The reclosers shall meet the conditions of continuous current rating and limits of observable temperature rise as specified in 5.4.1 and 5.4.2, respectively, when tested as specified in 6.1 and as follows:

6.9.1 Test Conditions

The device shall be mounted in a closed room substantially free from air currents other than those generated by heat from the device being tested.

6.9.2 Electrical Connections

The recloser shall have a bare conductor connected to each terminal, having a minimum length of 1.2 m (4 ft), specified for the recloser being tested, as given in Table 12, for reclosers with bushings designed for connection to bare conductors. The connection shall be made to the ends of these conductors.

For reclosers with separable cable connection bushings, the connecting conductors shall have a minimum length of 1.2 m (4 ft), and shall be of aluminum with sizes as shown in Table 13 (or equivalent).

6.9.3 Test Procedure

The rated continuous current of a recloser at rated frequency shall be applied continuously until the temperature becomes constant. The temperature shall be considered constant when three consecutive values of temperature rise taken at one-half hour intervals at all points where readings are being taken show a maximum variation of one degree. If the temperature rise after the second interval is equal to the limit of observable temperature rise (5.4.2) and if the temperature rise has increased since the last reading, the tests shall be continued. All temperature determinations shall be made as follows:

Table 12— Size of Bare Copper Leads

Rated Continuous Current, (A)	Size of Leads
Up to 50	AWG No 6 Solid
70 – 100	AWG No 2/0 Stranded
140 – 200	AWG No 4/0 Stranded
280	(125 mm ²) (250 000)
400	(200 mm ²) (400 000)
560	(300 mm ²) (600 000)
800	(500 mm ²) (1 000 000)
1120	(1000 mm ²) (2 000 000)

Table 13— Size of Aluminum Cable Leads

Rated Continuous Current, (A)	Size of Leads
200	AWG No 4/0 Stranded
560	1 000 000 Cmil (500 mm ²)

6.9.3.1 Method of Temperature Determination

This method consists of the determination of the temperature by thermocouples applied to the hottest part of the apparatus.

6.9.3.2 Value of Ambient Temperature During Test

- 1) The ambient temperature shall be taken as that of surrounding air, which should not be less than 10 °C nor more than 40 °C
- 2) Corrections shall not be applied for any variations in ambient temperature within the range specified in (1), above
- 3) Temperature tests may be made at ambient temperatures outside the range specified, if suitable and agreed upon correction factors are available

6.9.3.3 Determination of the Ambient Temperature

6.9.3.3.1 Placing of Thermocouples

The ambient temperature shall be determined by taking the average of the readings of three thermocouples (thermometers) placed 30 cm (12 in) to one side of the device and vertically located as follows:

- 1) One 30 cm (12 in) above the device
- 2) One 30 cm (12 in) below the device
- 3) One midway between the above two positions

6.9.3.3.2 Use of Oil Cup

In order to avoid errors due to the time lag between the temperature of apparatus and the variations in the ambient temperature, all reasonable precautions must be taken to reduce these variations and the errors arising therefrom. Thus, when the ambient temperature is subject to such variations that error in taking the temperature rise might result, the thermocouple for determining the ambient temperature should be immersed in a suitable liquid (such as oil) in a suitable heavy cup.

A convenient form for such an oil cup consists of a metal cylinder with a hole drilled partly through it. This hole is filled with oil and the thermocouple is placed therein. The response of the thermocouple to various rates of temperature change will depend largely upon the size, kind of material, and the mass of the containing cup and may be further regulated by adjusting the amount of oil in the cup. The larger the apparatus under test, the larger the metal cylinder employed as an oil cup in the determination of the cooling air temperature should be. The smallest size of oil cup employed in any case shall consist of a metal cylinder 2.5 cm (1 in) in diameter and 5 cm (2 in) high.

6.10 Time-Current Tests

6.10.1 Test Conditions

The time-current test conditions shall be as specified in 6.1 and as follows, except the mounting and grounding requirements are not obligatory.

The current range for which data shall be obtained shall be from the minimum tripping current to the rated interrupting current.

The temperature of the oil in reclosers with hydraulic timers shall be $25\text{ }^{\circ}\text{C} \pm 2\text{ }^{\circ}\text{C}$ at the start of the test.

6.10.2 Test Procedure

Time-current tests shall be conducted as follows (see Fig 1):

6.10.2.1 Contact Parting Time-Current Tests

Contact parting time-current tests shall be made at any voltage up to the rated maximum voltage of the recloser being tested with the test circuit so arranged that current through the recloser is held essentially at a constant value.

6.10.2.2 Clearing Time-Current Data

Clearing time-current data shall be determined by either method A or B.

Method A: Adding arcing time to the contact parting time obtained in 6.10.2.1. Arcing time may be obtained from oscillograms taken in making interrupting or operating duty tests.

Method B: Measuring the total clearing time from oscillograms of interrupting tests taken at rated maximum voltage and at currents ranging from minimum trip to rated symmetrical interrupting rating.

6.10.2.3 Measurement of Current During Time-Current Tests

The measurement of current through the recloser during a time-current test shall be made as follows:

- 1) A current existing for 1 s or more may be measured with a standard indicating ammeter.
NOTE — A standard ammeter equipped with an adjustable stop to reduce the movement of the needle during test will improve the accuracy of the measurement.
- 2) A current of less than 1 s duration shall be measured with an oscillograph, or other suitable instrument, and the current wave including the direct-current component of current and the alternating-current decrement shall be corrected to steady-state conditions for plotting the time curves.

6.10.2.4 Measurement of Time During Time-Current Tests

The measurement of the time shall be made as follows:

- 1) A time longer than 10 s may be measured with a stop watch, electric clock, timer or equivalent
- 2) A time between 1 and 10 s may be measured with a synchronous timer or equivalent
- 3) A time shorter than 1 s shall be measured with an oscillograph or other suitable instrument

6.10.3 Presentation of Data Standard Time-Current Curves

The results of time-current tests shall be presented as time-current curves on log-log paper.⁷ The curves shall show:

- 1) The clearing time for each instantaneous or fast and time delayed time-current curve
- 2) The voltage at which the tests are made when plotted on the basis of method B, 6.10.2.2
- 3) The type and rating of recloser for which curve data apply
- 4) The current range from minimum pickup current to the rated interrupting current
- 5) Tolerances
 - a) Instantaneous or fast clearing time-current curves, or both, for reclosers shall be plotted to maximum test values.
 - b) Time delay clearing time-current curves for all reclosers shall be plotted to average test values. Permissible tolerance from curves are $\pm 10\%$ of time or current, whichever is greater.

6.11 Mechanical Operations Tests

The recloser shall meet the conditions of mechanical duty when tested in accordance with 6.1.1, 6.1.2 and 6.1.3 and as follows:

6.11.1 Mechanical Duty Test

The recloser shall be subjected to a minimum of 2000 unit operations without maintenance. The recloser shall be adjusted for the maximum permissible number of unit operations to lockout. If the reclosing intervals are adjustable, these shall be set for the minimum reclosing intervals for which the recloser is designed.

6.11.2 Condition of Recloser Following Mechanical Operation Test

The recloser shall be capable of automatic and manual operation.

⁷Keuffel and Esser No 485258 or equivalent.

6.12 Cable Charging Current Interrupting Test

6.12.1 Purpose

Reclosers rated for operation on grounded Y cable circuits shall be capable of interrupting the charging current of unloaded lengths of single-phase shielded cable. The purpose of this test is to demonstrate the capability of interrupting the capacitive switching current rating of the recloser.

6.12.2 Test Conditions

The test circuit for cable charging currents shall be as shown in Fig 3. This circuit will simulate an unloaded shielded cable with the shield grounded.

Tests on single-phase reclosers shall be made at the phase-to-neutral voltage corresponding to the rated maximum voltage, as shown in Tables 2, 4 and 6.

6.12.3 Test Procedure

With the source terminals of the recloser energized, the recloser shall be closed. After the closing transient has subsided, the recloser shall be opened by means of the manual operating handle, or by means of the shunt trip, if the recloser is so equipped. At least 20 randomly timed close-open operations shall be performed.

6.12.4 Performance

Recloser performance is acceptable if it successfully interrupts the required capacitive currents. The maximum transient overvoltage produced during the tests shall not exceed 2.5 times the peak line-to-ground voltage.

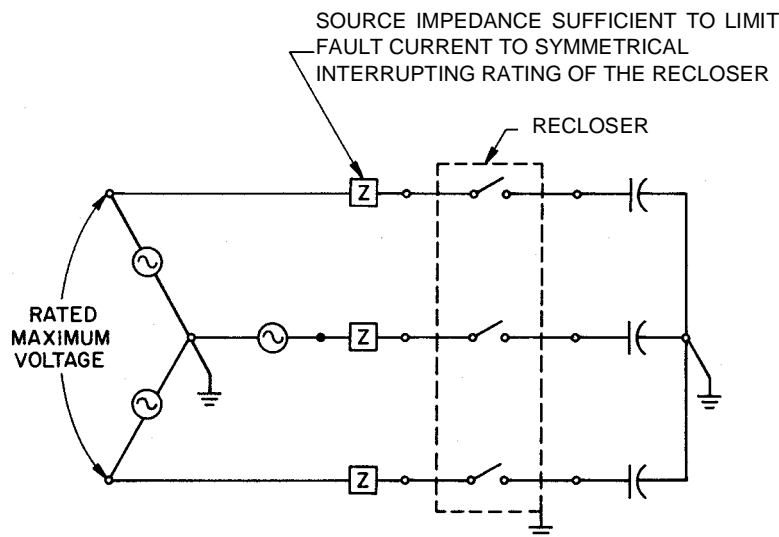
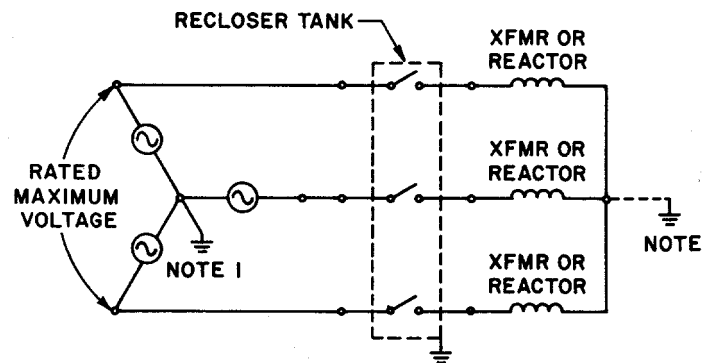
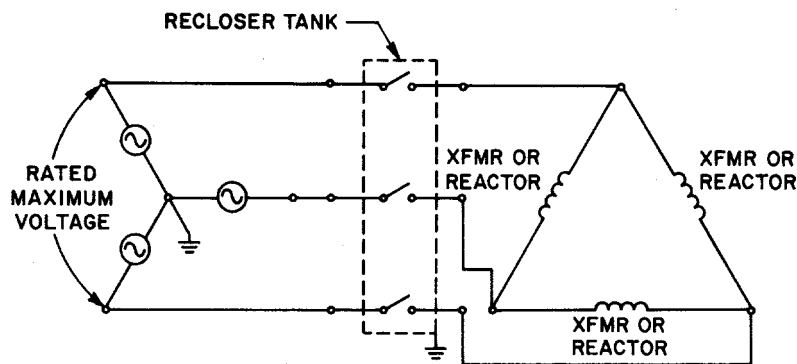

Figure 3— Circuit for Cable Charging Current Interruption Test



NOTE: Either the neutral of the load or the source is to be grounded but not both.

(a)



(b)

Figure 4— Magnetizing Current Test Circuits

6.13 Transformer Magnetizing Current Interruption Test

Reclosers shall be capable of interrupting magnetizing currents equal to $3\frac{1}{2}\%$ ($\pm\frac{1}{2}\%$) of the continuous current rating of the recloser.

6.13.1 Test Conditions

The test circuit for transformer magnetizing current interruption shall be as shown in Fig 4 (a) or 4 (b). Tests on single-phase reclosers shall be made at the rated maximum voltage of the recloser.

6.13.2 Test Procedure

With the source terminal of the recloser energized, the recloser shall be closed. After the closing transient has subsided, the recloser shall be opened by means of the manual operating handle, or by means of the shunt trip, if the recloser is so equipped. At least 20 randomly timed close-open operations shall be performed.

6.13.3 Performance

The performance of the recloser is acceptable if it successfully interrupts the required magnetizing current.

6.14 Control Elements Surge Withstand Capability Tests

Control elements supplied with shunt trip reclosers shall withstand, without damage, voltage surges originating in the low-voltage energy source, in the current or voltage, or both, transformers connected to the control elements, or in the control leads connecting the recloser and the control elements. Either of the tests described below may be used to demonstrate this capability.

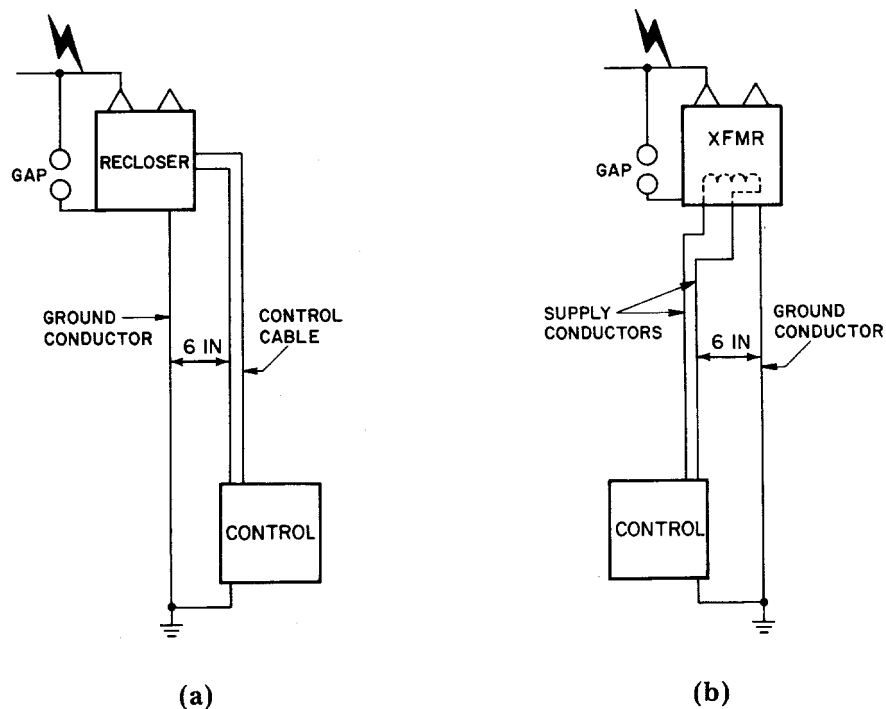

Figure 5— Surge Withstand Test Circuit-Control

6.14.1 Oscillatory Surge Tests

The test wave for this test shall be oscillatory, with a frequency of 1.0 to 1.5 MHz, a crest value of 2.5 to 3.0 kV occurring in the first half cycle, decaying to 50% of the crest value of the first peak in not less than 6 μ s. The source impedance of the surge generator used to produce the test wave shall be 150 Ω .

NOTES:

- 1 — All voltage and time values refer to the open circuit condition of the surge generator.
- 2 — Time period and repetition rate have been chosen to cover equipment which is used on 50 Hz as well as 60 Hz systems.

6.14.1.1 Test Procedure

The test wave shall be applied to those control element terminals used to connect the control elements to all instrument transformers, sources of energy, and any other connected element external to the control cabinet, and shall be applied

between each pair of terminals and between each terminal and ground. During these tests, the recloser and control elements shall be connected for normal operation and shall be energized at rated voltage.

6.14.2 Simulated Surge Arrester Operation Test

This test simulates a lightning arrester operation and the resulting voltage changes that appear on the recloser and control elements due to the rate of current change and the impedance of the ground connection.

6.14.2.1 Test Procedure

A gap connected from one source bushing terminal to the recloser ground lead shall be used to simulate a surge arrester. See Fig 5 (a). The gap shall be set to flashover at 80% ($\pm 10\%$) of the rated impulse withstand voltage of the recloser on which the control element is to be applied. The surge voltage shall rise to flashover in $1.2 \mu\text{s}$ ($\pm 1/2 \mu\text{s}$). The external surge generator current limiting resistance shall be chosen to provide a surge current following the gap flashover having a peak value of 7000 A ($\pm 10\%$).⁸

The recloser ground lead shall be 6 m (20 ft) of AWG No 12 copper wire. The control cable shall be of equal length and spaced 15 cm (6 in) from and run parallel to the recloser ground lead.

Fifteen positive and fifteen negative surges shall be applied to the source bushing with the recloser open. Fifteen positive and fifteen negative surges shall be applied to the load bushing with the recloser closed.

The above tests shall also be applied to a properly rated transformer, connected as shown in Fig 5(b). Fifteen positive and fifteen negative surges shall be applied.

6.14.3 Condition of Control During and After Test

The control shall not close the recloser from an open position during the application of surges. Tripping from a closed position is permissible on a reclosing switchgear device. Malfunction of the control to cause lockout on one surge is not permissible.

Following the tests, the recloser and control apparatus shall be capable of performing all normal functions without impairment.

7. Production Tests

All applicable production tests shall be made by the manufacturer on each recloser, or representative sample, at the factory after final assembly. Production tests shall include the following:

- 1) Calibration
- 2) Control, Secondary Wiring and Accessory Device Test
- 3) Dielectric Withstand Test; One Minute Dry Low Frequency
- 4) No Load Operation Test
- 5) Leak Test; submersible reclosers only

⁸This value of surge current was selected because it was the maximum available using existing laboratory facilities. However, experience has shown good correlation between field performance and laboratory test results using this value.

7.1 Reclosing and Overcurrent Trip Calibration

Reclosers shall be subjected to the following calibration, where applicable, for conformance to published time-current characteristic curves. Calibration may be performed on the individual control elements sub-assembly prior to final assembly on the recloser. When the latter is done, the effect of the operating time on the recloser shall be recognized, and the complete assembly shall be tested to assure that the device will trip the recloser. Sinusoidal wave shape, 60 Hz current at a convenient voltage shall be used. The calibration may be performed in any order deemed appropriate by the manufacturer.

- 1) Minimum tripping current test (see 6.5)
- 2) Trip settings
- 3) Time current tests (see 6.10.2.1)
- 4) Sequencing tests
- 5) Remote features
- 6) Special features

7.2 Control, Secondary Wiring and Accessory Devices Check Tests

Control, secondary wiring and accessory devices shall be checked to ensure that all connections have been made correctly. Devices and relays, if needed, shall be checked by actual operation where feasible. Those circuits for which operation is not feasible shall be checked for continuity.

7.3 Dielectric Withstand Test; One Minute Dry Low Frequency

The test shall be conducted in accordance with 6.2.1—(2). The duration of the test may be 1 s if a voltage of 20% above that specified in 6.2.1—(2) is used.

7.4 Mechanical Operations Tests

The mechanical operations tests shall include the following:

- 1) Inspection of the external parts
- 2) Manual tripping by the tripping lever
- 3) Without trouble or malfunction, 25 consecutive operational tests to check performance of a mechanism, sequencing, and time devices. On shunt trip reclosers, 5 operations shall be at maximum control voltage

7.5 Leak Test

A suitable leak test shall be performed on submersible reclosers to ensure that these will operate under service conditions as outlined in 3.1(3).

8. Construction Requirements

8.1 Tank Construction; Submersible or Dry Vault Reclosers

8.1.1

The tank and all appurtenances shall be made of corrosion resistant material or provided with an impact and corrosion resistant finish and should also be suitable for storage in uncovered areas.

8.1.2

External parts of the tank or accessories shall not trap or hold water.

8.1.3

Tank support rails shall extend entirely across the bottom of the recloser tank to increase protection and to provide a firm, stable support. The support shall include provision for anchoring the tank.

8.1.4

Lifting lugs shall be provided and so positioned that the recloser will remain level when being lifted. They shall be designed and located on the tank to avoid interference between lifting slings and any attachments (bushings, operating handles, etc), and to avoid scratching or marring the tank finish during handling.

8.1.5

Tank construction shall be such that leaks will not occur and the recloser will remain mechanically operable at the maximum operating pressure generated by the normal operation of the recloser (for example, temperature rise, load interrupting and fault closing).

8.2 Grounding Provisions

A recloser with a metal housing shall have provisions for the connection of a ground lead.

The ground connector shall accommodate a ground conductor of a size adequate to conduct the rated interrupting current of the recloser for a period of 3 s without damage to the conductor or connector.

Pad mounted, dry vault and submersible reclosers shall have an additional grounding connection for each three-phase set of cable entrances.

8.3 Insulating Medium Quantity Indicators (Submersible Reclosers)

When liquid or gas is used as the insulating medium, provision shall be made for personnel to determine readily the insulating liquid level or insulating gas pressure with the recloser energized. Indicator markings shall show the safe operating range of levels or pressures. Procedures or devices which require exposing the insulating medium to the outside environment shall not be used.

8.4 Oil Sampling Provisions (Submersible Reclosers)

When oil is used as the insulating medium, provision shall be made to obtain a bottom oil sample.

8.5 Manual Operating Provision

Reclosers shall be provided with a manual operating lever which is suitable for operation with a hot line stick, or other suitable manual operating means.

8.5.1 Submersible or Dry Vault Recloser

The operating handle on a submersible recloser shall be located such that one man standing on the surface can operate it without standing directly over the recloser.

8.5.2 Pad Mounted Reclosers

Pad mounted reclosers with draw-out provisions shall include an interlock which requires manual tripping of the recloser before the primary connections can be disengaged.

8.6 Position Indicator

A recloser shall be provided with a position indicator, or other suitable means, which clearly indicates its closed, or open position and shall be visible from the surface. For pad mounted, dry vault or submersible reclosers viewing of the position indicator may require opening of the enclosure. If colors are used to indicate an *open* or *closed* position, red shall signify closed and green signify open, with the words OPEN or CLOSED in contrasting colors.

8.7 Nameplate Markings

The following minimum information shall be given on the nameplate:

- 1) Manufacturer's name or trademark
- 2) Manufacturer's type or identification number to indicate the design or construction. Changes in operating characteristics, design, or construction, which affect its application or service, shall be accomplished by a change in the identification data
- 3) Rated maximum voltage
- 4) Rated continuous current
- 5) Rated minimum tripping current (series trip-coil reclosers only)
- 6) Rated symmetrical interrupting current
- 7) Rated impulse withstand voltage

For submersible reclosers, a nameplate of stainless steel or other corrosion resistant material shall be provided. The nameplate shall be securely attached to the top of the tank by means of stainless steel screws, rivets, or other corrosion resistant fasteners. All letters, schematics and numbers shall be permanently stamped, embossed or engraved on the nameplate.

8.8 Stored Energy Mechanism Charge Indicator

When indicators are used on stored energy operating mechanisms, the following colors shall be used:

- 1) Yellow background with CHARGED in black letters for charged mechanisms
- 2) White background with DISCHARGED in black letters for discharged mechanisms

8.9 Safety Provisions

Pad mounted reclosers shall conform to the requirements specified for category A equipment as defined in ANSI/IEEE C37.100-1981 [4].

8.10 Separate Mounting of Control Apparatus

Where applied, control apparatus shall be capable of being mounted separately from the recloser in normal service.

8.11 Counters

An operations counter shall be provided to indicate the total number of operations of the recloser. The counter shall be visible with the recloser in service.

8.12 Conductor Terminal Sizes

For connection of bare conductors, bushing terminals shall accommodate conductors of a size adequate to conduct the rated continuous current of the recloser without exceeding the appropriate temperature rise shown in 5.4.2.

For submersible reclosers, bushings shall accommodate cable terminations in accordance with ANSI/IEEE Std 386-1977 [5].

8.13 Vacuum Interrupters

Where vacuum interrupters are used, they shall be in accordance with ANSI C37.85-1972 [1]. X-radiation generated shall not exceed the value in Table 1 of that standard.